

THE FOLLOWING CODES ARE TO BE MET WHEN REQUIRED:

1. FLORIDA BUILDING CODE - RESIDENTIAL 2023, 8TH ED. CHAPTER 42 & CHAPTER 45: SECTION R4501.
2. FLORIDA BUILDING CODE - MECHANICAL 2023, 8TH ED.
3. FLORIDA BUILDING CODE - PLUMBING 2023, 8TH ED.
4. FLORIDA BUILDING CODE - FUEL GAS 2023, 8TH ED.
5. FLORIDA BUILDING CODE- ENERGY CONSERVATION 2023, 8TH ED.
6. 2020 NATIONAL ELECTRIC CODE
6. ANS/ APSP/ ICC - 3, 4, 5, 6, 7, 15, 16

GENERAL DESIGN/ CONSTRUCTION REQUIREMENTS

- POOL INSTALLATION SHALL BE BY A QUALIFIED AND LICENSED (APPROVED BY LOCAL BUILDING DEPARTMENT AND CERTIFIED POOL CONTRACTOR. THE INSTALLATION SHALL CONFORM TO ALL STATE AND LOCAL BUILDING CODES, AS WELL AS TENANTS OF ANY ASSOCIATION WITH JURISDICTION.
- CIRCULATION SYSTEM, COMPONENTS AND EQUIPMENT SHALL COMPLY WITH NSF 50.
- PUMPS 3 HP AND LESS SHALL MEET ANS/UL1081, CORROSION RESISTANT WITH STRAINER AND MEET THE REQUIRED FLOW.
- SURFACE SKIMMERS SHALL MEET NSF 50 AND THERE SHALL BE ONE FOR EVERY 800 SQUARE FEET OF SURFACE AREA.
- RETURN INLETS SHALL BE A MINIMUM OF ONE FOR EVERY 600 SQUARE FEET.
- HEATERS SHALL MEET ANS/221.56 OR UL 1261 OR UL559.
- DISINFECTANT EQUIPMENT SHALL COMPLY WITH NSF 50.
- PRESSURE TEST PIPING AT 35 PSI FOR 15 MINUTES.
- WATER SUPPLY AND DISPOSAL SHALL BE SO ARRANGED THAT THERE IS NO CROSS CONNECTION WITH DOMESTIC SERVICE.
- CONCRETE SHALL BE MIN. 2500 PSI AT 28 DAYS.
- DECK SLAB TO HAVE 6X6, #10/10 W.W.M. OR EQUAL SUSPENDED IN CONCRETE.
- FIBER MESH CONC. MAY BE USED IN LIEU OF 6X6 10X10 W.W.M. AS ALLOWED BY LOCAL CODE.
- POOL SHALL BEAR ON UNDISTURBED SOIL, FREE OF PEAT, MUCK, OR OTHER DELETERIOUS MATERIAL OF ANY SIGNIFICANT AMOUNT.
- BACKFILL SHALL HAVE BEARING VALUE GREATER THAT 60 PSF WITH VERTICAL ANGLE OF REPOSE. BACK-FILL MATERIAL (CLEAN SAND, FLOWABLE FILL OR GRAVEL) MUST NOT CONTAIN ROCK GRAVEL GREATER THAN 3/4TH INCH. BACK-FILL SHALL BE INSTALLED AND COMPACTED IN LIFTS TO MATCH WATER LEVEL IN POOL AND NOT DEFORM POOL.
- POOL TURNOVER SHALL BE 12 HOURS MAXIMUM WITH CARTRIDGE FILTER AND PROPERLY GROUNDED APPROVED PUMP. POOL PUMP TO BE ABOVE GROUND WITH WEATHER PROTECTIVE HOUSING.
- ENTIRE SPA WATER CAPACITY SHALL HAVE DESIGNED TURN OVER CAPACITY OF AT LEAST ONCE PER HOUR, BASED ON THE MANUFACTURER'S SPECIFIED RATE OF THE FILTER IN A CLEAN MEDIA CONDITON OF THE FILTER.
- ALL PIPE TO BE PVC SCHEDULE 40 SUITABLE FOR POTABLE WATER, OR TO LOCAL CODE.
- DIRECT SUCTION PIPES FROM THE POOL SHALL HAVE SECONDARY RELIEFS.
- MAX. VELOCITY IN PRESSURE PIPING TO BE 10 FEET PER SECOND.
- MAX. VELOCITY IN SUCTION PIPING TO BE 8 FEET PER SECOND.
- MAIN DRAIN COVER TO BE CERTIFIED AS COMPLIANT WITH ANS/ASME A112.19.8M OR A GRATE WITH A MINIMUM OPEN AREA OF 144 SQ.IN. OR AS TO LOCAL CODES, SECURELY FASTENED IN PLACE.
- HYDROSTATIC PRESSURES: DESIGN ASSUMED POOL IS ALWAYS FULL, WITH ANY REQUIRED HOLD DOWNS AND REINFORCING BY OTHERS.
- HYDROSTATIC RELIEF VALVE NOT CREDITED FOR MORE THAN 2 FEET OF THE DIFFERENCE OF HEAD BETWEEN POOL BOTTOM AND FLOOR CRITERIA LEVEL, USE WHERE CODE REQUIRES.
- SWIMMING POOL SKIMMER(S) SHALL HAVE DECK OPENINGS.
- ALL ELECTRICAL SHALL CONFORM TO N.E.C. 2020. NO OVERHEAD WIRES SHALL PASS WITHIN 10 FEET OF POOL.
- ELECTRICAL HOOK-UP OF POOL EQUIPMENT, RAIL, BOXES, ETC. AND GROUNDING OF DECK STEEL SHALL BE IN ACCORDANCE WITH THE NATIONAL ELECTRICAL CODE AND ALL APPLICABLE STATE AND LOCAL BUILDING CODES BY A LICENSED ELECTRICAL CONTRACTOR.
- INSTALL 12-VOLT LIGHT. WHEN ALLOWED BY LOCAL CODE HIGHER VOLTAGE SHALL BE GFI PROTECTED PER 2020 NEC. AT INSTALLERS OPTION LED OR FIBEROPTIC LIGHTING MAY BE USED.
- STEPS (10" MINIMUM TREAD WITH 240 SQUARE INCH MINIMUM AREA, 12" RISER WITH INTERMEDIATE TREADS AND RISERS UNIFORM) OR LADDERS SHALL BE PROVIDED AT EACH END OF POOL PER CODE.
- POOL LADDERS SHALL BE CORROSION RESISTANT WITH NON-SLIP TREADS. HANDRAILS AND LADDERS SHALL HAVE NO.8 SOLID COPPER GROUNDS AND SOLIDLY IMBEDDED ANCHORS.
- STEPS, TREADS, AND RISERS SHALL CONFORM TO LOCAL CODES WHEN DIFFERENT THEN THAT SHOWN.
- THERAPY SEATS, WHERE INSTALLED, SHALL BE RECESSED INTO THE SIDES OF SUCH POOL NOT MORE THAN 20 INCHES BELOW WATER LEVEL, AND IN SUCH A MANNER AS TO CLEARLY DISTINGUISH SUCH UNDERWATER OBSTRUCTIONS FROM POOL AREAS INTO WHICH PERSONS MAY DIVE.
- IF THE SLOPE FROM SHALLOW END TO DEEP END IS MORE THAN 1:7 A SAFETY ROPE SHALL BE PROVIDED WHEN REQUIRED.
- SUPPORTS AND STEPS SHALL BE PROPERLY REINFORCED AND OF SUFFICIENT STRUCTURAL STRENGTH TO SAFELY CARRY ALL ANTICIPATED LOADS.
- ALL GLASS WITHIN 5' OF WATERS EDGE SHALL COMPLY BUILDING CODE REQUIREMENT.
- POOL SHALL NOT BE DRAINED WITHOUT CONSULTING POOL CONTRACTOR OR ENGINEER.
- DIVING PLATFORMS OR DIVING BOARDS ARE NOT TO BE INSTALLED ON POOL. POOL NOT DESIGNED FOR DIVING.

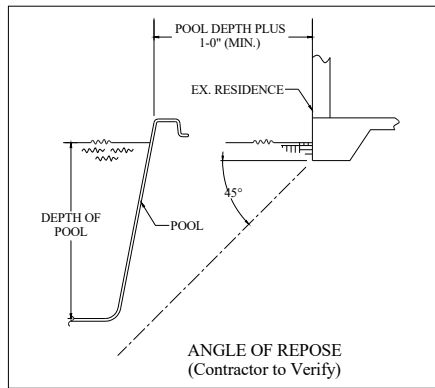

SITE NOTE:

FINAL LOCATION AND ELEVATION BY CONTRACTOR. CONTRACTOR MAY REQUIRE TO PROVIDE A SEPARATE SITE PLAN PER LOCAL REQUIREMENTS.

PROVIDE APPROVED HYDROSTATIC VALVE WHEN POOL IS INSTALLED AT LOCATION OF HIGH GROUND WATER.

CONTRACTOR SHALL DETERMINE THE NECESSITY OF SPECIAL POOL ANCHORAGE ON SITE AND CONSULT WITH ENGINEER FOR SITE-SPECIFIC DETAILS.

FBC 1804.1 EXCAVATION NEAR FOUNDATIONS (WHEN APPLICABLE): EXCAVATION FOR ANY PURPOSE SHALL NOT REDUCE VERTICAL OR LATERAL SUPPORT FOR ANY FOUNDATION OR ADJACENT FOUNDATION WITHOUT FIRST UNDERPINNING OR PROTECTING THE FOUNDATION AGAINST DETERMENTAL LATERAL OR VERTICAL MOVEMENT, OR BOTH.

TYPICAL PROPERTIES OF A REINFORCED FIBERGLASS POOL:

BARCOL HARDNESS OF 30 MIL. GEL COAT	40 - 50
GLASS CONTENT BY WEIGHT	27%
TENSILE STRENGTH, PSI AT 77F	19,500
TENSILE ELONGATION	1 - 2%
FLEXURAL STRENGTH, PSI AT 77F	23,800 - 27,600
FLEXURAL MODULUS, PSI X 10 AT 77F	0.72 - 0.77
IZOD IMPACT FR - LBS/ INCH OF NOTCH	5.9
COMPRESSIVE STRENGTH, PSI	25,000 TO 38,000
TYPICAL THICKNESS INCHES	3/8"

FIBERGLASS POOL STRUCTURAL NOTE:

FIBERGLASS STRUCTURAL DETAILS BY OTHERS. REFER MANUFACTURER'S SPECS. & RELEVANT ESR REPORTS.

EQUIPOTENTIAL BONDING SHALL CONFORM TO 2020 NEC SECTION 680.26.

FOR ALL WALKING SURFACES LOCATED MORE THAN 30" ABOVE GRADE, GUARDS SHALL BE PROVIDED PER FBC R312.

OUTDOOR RESIDENTIAL SWIMMING POOLS SHALL BE PROVIDED WITH A BARRIER COMPLYING WITH FBC R4501.17.1.1 THROUGH R4501.17.1.14.

WHERE A WALL OF DWELLING SERVES AS PART OF THE BARRIER, ONE OF THE FOLLOWING SHALL APPLY:
 1) ALL DOORS AND WINDOWS PROVIDING DIRECT ACCESS FROM THE HOME/ DWELLING TO THE POOL SHALL BE EQUIPPED W/ AN EXIT ALARM COMPLYING W/ UL 2017.
 2) ALL DOORS PROVIDING DIRECT ACCESS FROM THE HOME TO THE POOL MUST BE EQUIPPED W/ A SELF-CLOSING, SELF-LATCHING DEVICE W/ POSITIVE MECHANICAL LATCHING/ LOCKING INSTALLED A MIN. OF 54 INCHES ABOVE THE THRESHOLD, WHICH IS APPROVED BY THE AUTHORITY HAVING JURISDICTION.
 3) A SWIMMING POOL ALARM THAT COMPLIES TO ASTM STANDARD F2208.

ENTRY/ EXIT REQUIRED AT THE SHALLOW END AND DEEP END IF OVER 5 FEET DEEP. ACCEPTABLE ARE STAIRS (10" MINIMUM TREAD WITH 240 SQUARE INCH MINIMUM AREA, 12" RISER (MAX.) WITH INTERMEDIATE TREADS AND RISERS UNIFORM), LADDERS, UNDERWATER SEATS, AND SWIM-OUTS (MAXIMUM 20" BELOW WATERLINE).

ENTRAPMENT PROTECTION FOR SUCTION OUTLETS SHALL BE INSTALLED IN ACCORDANCE WITH THE REQUIREMENTS OF ANS/ APSP/ ICC-7 & FBC R4501.6.6.

BLOCKABLE DUAL OUTLETS (MAIN DRAINS) SHALL BE SEPARATED BY A MINIMUM OF 3 FEET MEASURED FROM CENTER TO CENTER OF THE SUCTION OUTLET FITTING ASSEMBLY (SOFA) OR LOCATED ON TWO (2) DIFFERENT PLANES I.E., ONE (1) ON THE BOTTOM AND ONE (1) ON THE VERTICAL WALL, OR ONE (1) EACH ON TWO (2) SEPARATE VERTICAL WALLS. SUCTION OUTLETS SHALL NOT BE INSTALLED IN SEATING AREAS.

AN UNBLOCKABLE SOFA REQUIRES THAT THE SUCTION OUTLET FITTING ASSEMBLY (SOFA) BE CERTIFIED AS UNBLOCKABLE, AND BE DESIGNED BY THE MANUFACTURER AS UNBLOCKABLE, AND THE MANUFACTURER'S INSTRUCTIONS MUST STATE THE SOFA IS AUTHORIZED FOR USE AS AN UNBLOCKABLE IN ACCORDANCE WITH ANS/ APSP/ ICC - 16 2017.

CONTRACTOR TO INSTALL ALL PRODUCTS PER MANUFACTURER'S SPECIFICATIONS

**SCOPE OF WORK:
RESIDENTIAL (NON-DIVING) POOL ENGINEERING**

FOR POOL VOLUME (MAX.)=15,000 GALS, MAX FLOW RATE = 62 GPM, AND TOTAL SIMPLIFIED TDH (MAX.) = 60 FT.,

EQUIPMENT LIST (AS LISTED OR EQUAL):

- PUMP: JANDY VS FLOPRO 1.85 HP
- MAIN DRAIN: CMP MODEL # 25215-00X-000
- MAIN DRAIN MAX. FLOW RATE = 128 GPM (FLOOR), 124 GPM (WALL)

FIBERGLASS POOL/ SPA/ TAN LEDGE MODELS

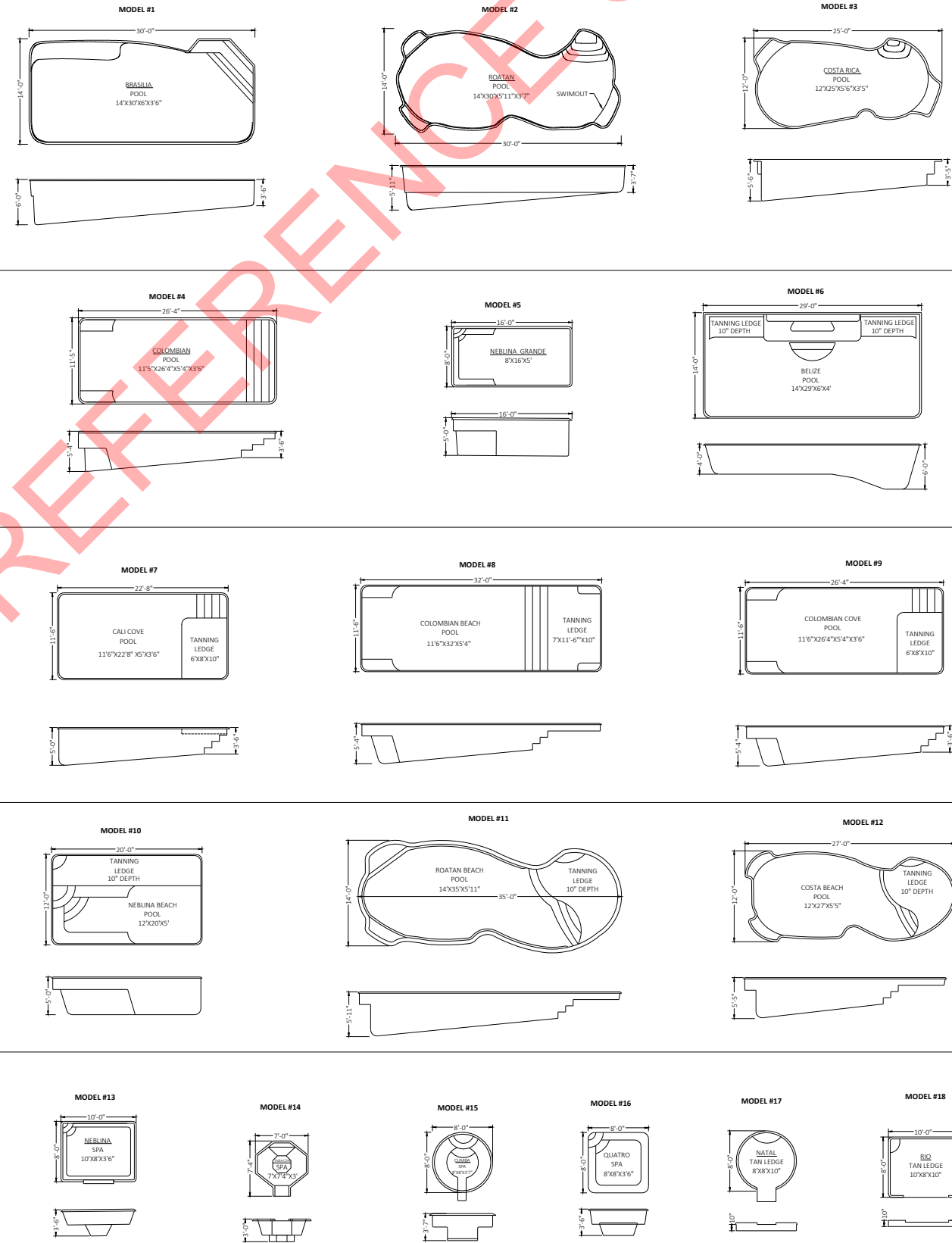

SHEET NO.	DRAWING INDEX
S/01	GENERAL NOTES/ MODELS
S/02	DETAILS

POOLS TO BE INSTALLED IN FLOOD HAZARD AREAS REQUIRES SITE-SPECIFIC ENGINEERING; CONTRACTOR SHALL CONSULT WITH ENGINEER.

(1) SET OF ENGINEERING PLANS IS VALID FOR (1) STRUCTURE ONLY AT A SITE-SPECIFIC ADDRESS. THESE PLANS, OR THE NOTES AND DETAILS HEREIN CAN NOT BE DUPLICATED OR REPLICATED WITHOUT THE SIGN AND SEAL OF FLORIDA ENGINEERING LLC (COA #30782)

GENERIC ENGINEERING PLANS REQUIRE RAISED SEAL & BLUE INK SIGNATURE. USE OF THESE PLANS WITHOUT SUCH SEAL AND SIGNATURE BY A PROFESSIONAL ENGINEER FROM FLORIDA ENGINEERING, LLC, IS UNAUTHORIZED AND MUST NOT BE APPROVED.

FLORIDA ENGINEERING LLC
 4161 TAMAMI TRAIL, UNIT 101
 PORT CHARLOTTE, FLORIDA 33952
 (941) 391-5980
 FLEng.com
 Orders@FLEng.com

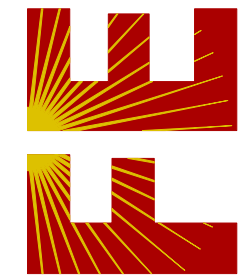

PROJECT NO. 24XXXXX

CA CERT. #30782

CONTRACTOR:
RAINFORST POOLS-N-COMPOSITES LLC
 5797 LAKE WINONA RD BLDNG-R
 DELEON SPRINGS, FL 32130

PROJECT ADDRESS:
GENERIC POOL PLAN

DESIGN DATE:	08/06/2024
REVISION 1:	DATE
REVISION 2:	DATE
DRAWN BY:	PD
SCALE:	NTS

SHEET :
01

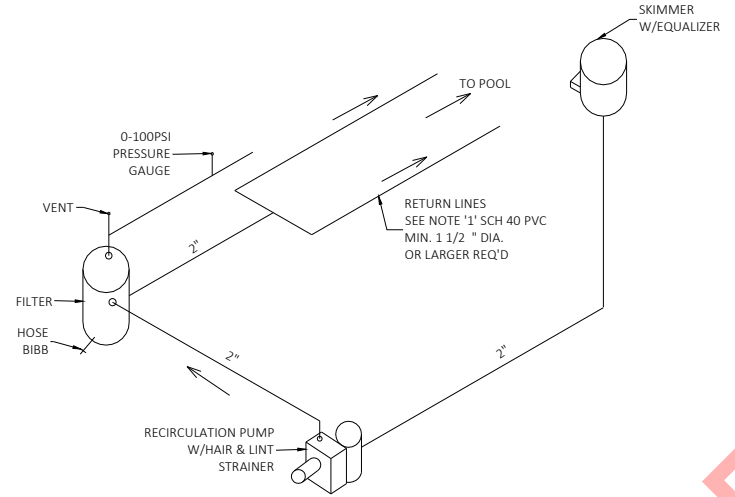
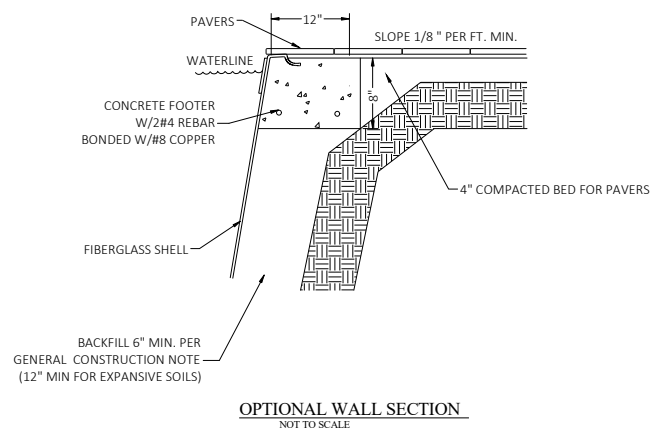
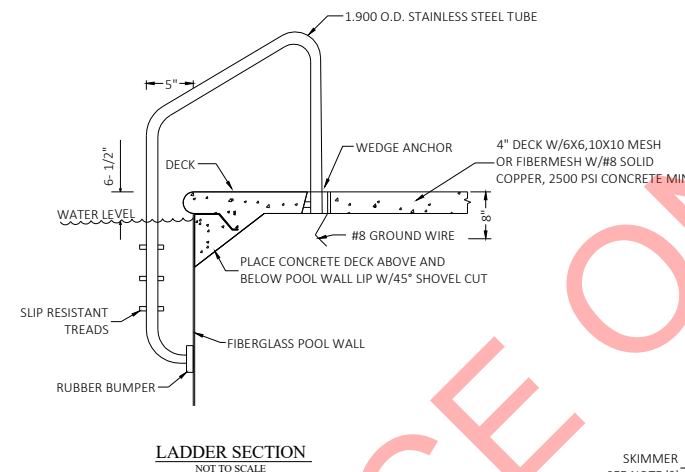
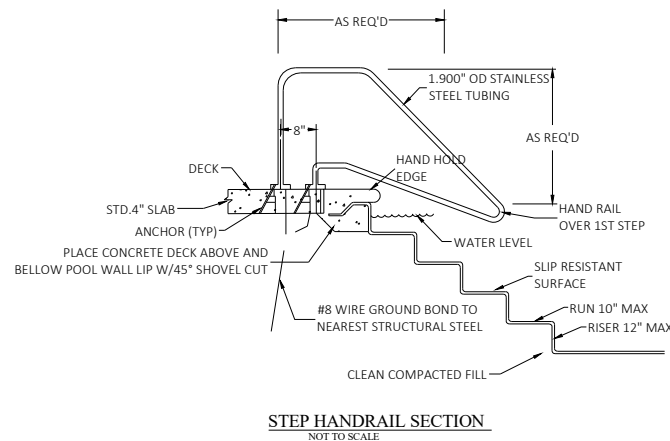
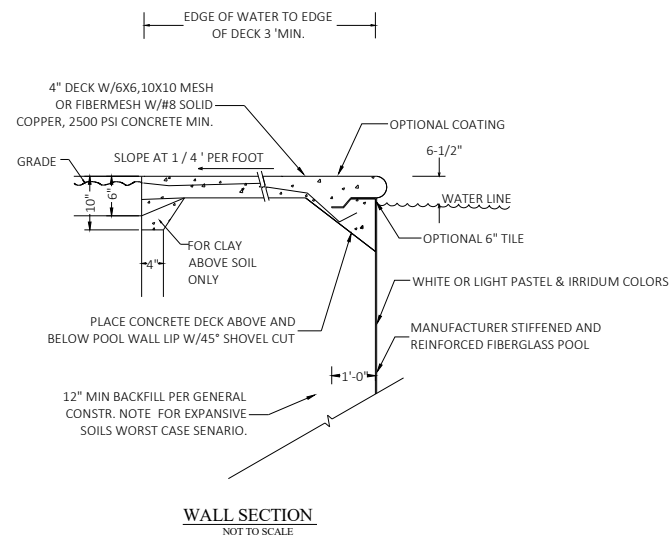

- NOTES:
- (1) AT LEAST ONE RETURN LINE IS REQUIRED FOR EVERY 300 SQ.FT. OF SURFACE AREA.
 - (2) SUMP LINE (WHEN REQ'D) TO BE 2" SCH. 40 PVC FROM 4 CUBIC FOOT GRAVEL BED BENEATH MAIN DRAIN TO 18" FROM EQUIPMENT.

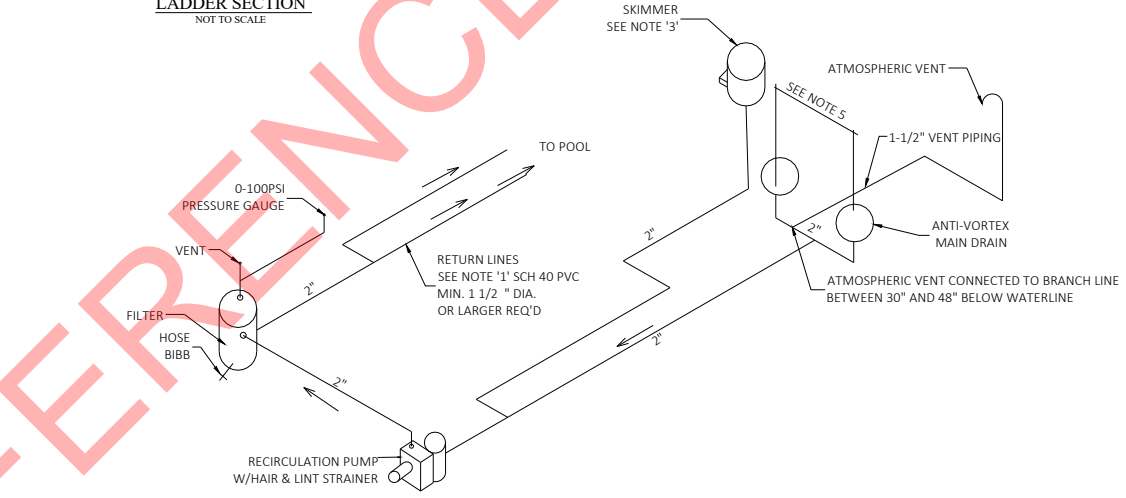

- NOTES:
- (1) AT LEAST ONE RETURN LINE IS REQUIRED FOR EVERY 300 SQ.FT. OF SURFACE AREA.
 - (2) SUMP LINE (WHEN REQ'D) TO BE 2" SCH. 40 PVC FROM 4 CUBIC FOOT GRAVEL BED BENEATH MAIN DRAIN TO 18" FROM EQUIPMENT.
 - (3) TWO SKIMMERS REQUIRED IF POOL AREA GREATER THAN 800 SF.
 - (4) MAIN DRAIN LOCATED NEAR DEEPEST PART OF THE POOL.
 - (5) POOL MUST HAVE MAIN DRAIN MINIMUM 3'-0" APART OR SEPARATED ON DIFFERENT PLANES.
 - (6) MAIN DRAINS MUST BE PLUMBED TOGETHER WITH A COMMON TO THE PUMP.

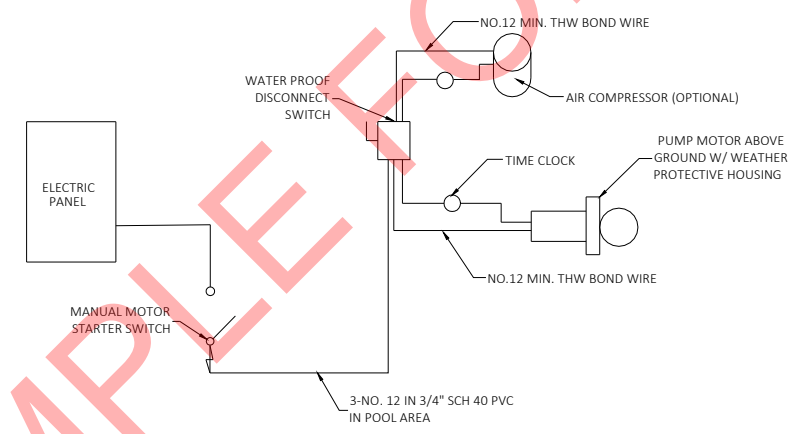
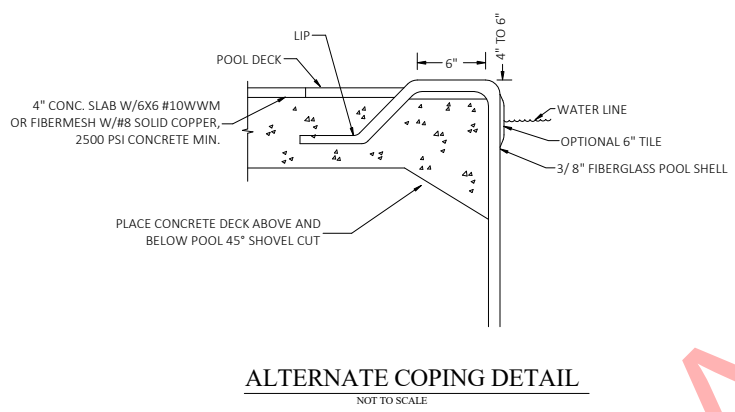

NOTE:
PRIOR TO ELECTRICAL ROUGH, LICENSED ELECTRICIAN TO FIELD VERIFY THAT PROPOSED POOL EQUIPMENT DOES NOT EXCEED EXISTING BREAKER'S AVAILABILITY. SITE SPECIFIC ELECTRICAL ENGINEERING IS REQUIRED TO REPLACE ANY EXISTING ELECTRICAL COMPONENTS.

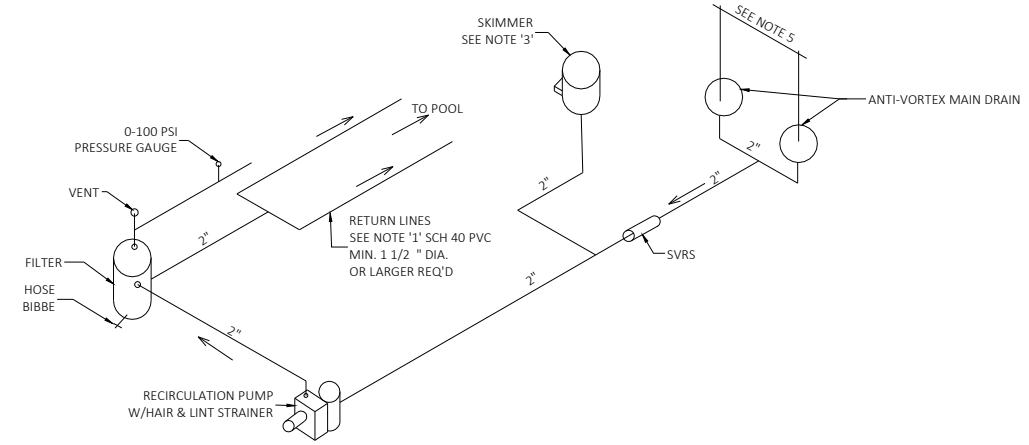

- NOTES:
- (1) AT LEAST ONE RETURN LINE IS REQUIRED FOR EVERY 300 SQ.FT. OF SURFACE AREA.
 - (2) SUMP LINE (WHEN REQ'D) TO BE 2" SCH. 40 PVC FROM 4 CUBIC FOOT GRAVEL BED BENEATH MAIN DRAIN TO 18" FROM EQUIPMENT.
 - (3) TWO SKIMMERS REQUIRED IF POOL AREA GREATER THAN 800 SF.
 - (4) SKIMMER AND MAIN DRAIN MUST BE PLUMBED TOGETHER WITH A COMMON LINE TO THE PUMP. SKIMMER AND MAIN DRAIN MUST NOT BE VALVED SEPARATELY.
 - (5) POOL MUST HAVE MAIN DRAIN MINIMUM 3'-0" APART OR SEPARATED ON DIFFERENT PLANES.
 - (6) MAIN DRAINS MUST BE PLUMBED TOGETHER WITH A COMMON LINE TO THE PUMP.

FLORIDA ENGINEERING LLC
4161 TAMiami TRAIL, UNIT 101
PORT CHARLOTTE, FLORIDA 33952
(941) 391-5980
FLEng.com
Orders@FLEng.com

PROJECT NO. 24XXXXX

CA CERT. #30782

RAINFORST POOLS-N-COMPOSITES LLC
5797 LAKE WINONA RD BLDNG-R
DELEON SPRINGS, FL 32130

PROJECT ADDRESS:
GENERIC POOL PLAN

CONTRACTOR:

DESIGN DATE: 08/06/2024

REVISION 1: DATE

REVISION 2: DATE

DRAWN BY: PD

SCALE: NTS

SHEET: 02